

NÜVÖ®

Whole Home Audio

Wireless Audio System



Product Guide



Table of Contents

Introduction	Page 3
P100 Zone Player Back Panel Features	Page 4
P200 Zone Player Back Panel Features	Page 4
P3100 Back Panel Features	Page 5
1. Setup/Installation	
1.1 Network Requirements	Page 5
1.2 Connecting the Gateway to the Network	Page 5
1.3 Hardwiring the Players Directly to the Network	Page 6
1.4 Installing the P3100 Zone Player	Page 7
1.5 Connecting the Speakers to the P100 and P200 Zone Players	Page 8
1.6 Connecting the Speakers to the P3100 Zone Player.....	Page 8
2. Setting Up a System from the iOS or Android App	
2.1 New Wireless System Setup	Page 9
2.2 Adding Zones to an Existing System	Page 12
2.3 Adding Additional Gateways to an Existing System	Page 13
3. Using the iOS and Android Control App	
3.1 The Dashboard	Page 14
3.2 Music Selection	Page 14
3.3 Bluetooth® Playback	Page 15
3.4 Line In	Page 15
4. The Settings Menu	
4.1 Zones	Page 16
4.2 Gateways	Page 18
4.3 Controller.....	Page 18
4.4 Add a NuVo Component.....	Page 19
4.5 Music Library	Page 19
4.6 Music Services.....	Page 20
4.7 System.....	Page 20
4.8 International.....	Page 21
4.9 Help	Page 22
5. The Music Share Software	Page 22
6. Troubleshooting	
6.1 Front Panel LEDs.....	Page 24
6.2 Not Connected	Page 24
6.3 Restoring Defaults	Page 25
6.4 Advanced Network Management	Page 25
7. Specifications	Page 26

The NuVo Wireless Audio System Product Guide

Introduction

Welcome to the exciting world of the NuVo Wireless Audio System. Now your favorite music, in any room you want it, anytime you want it, is as close as the touch of a button on the NuVo Controller or any of your Apple or Android Wi-Fi enabled portable devices. True high fidelity music, from your own personal library or streaming from the Internet, is more affordable and accessible than you ever imagined.

This is your guide to quickly and easily filling a home with music.

The NuVo Wireless Audio System

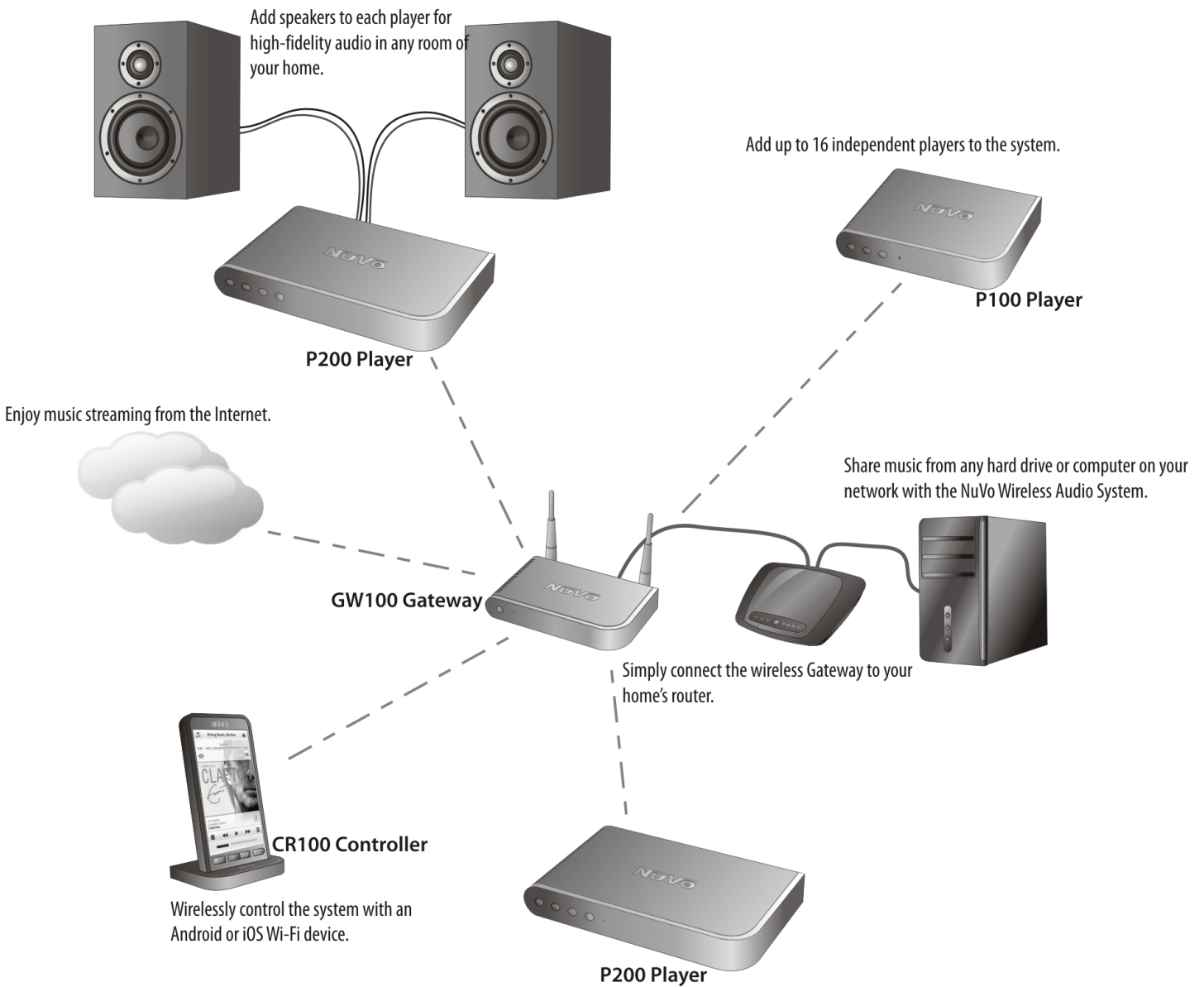

P100 Zone Player Back Panel Features

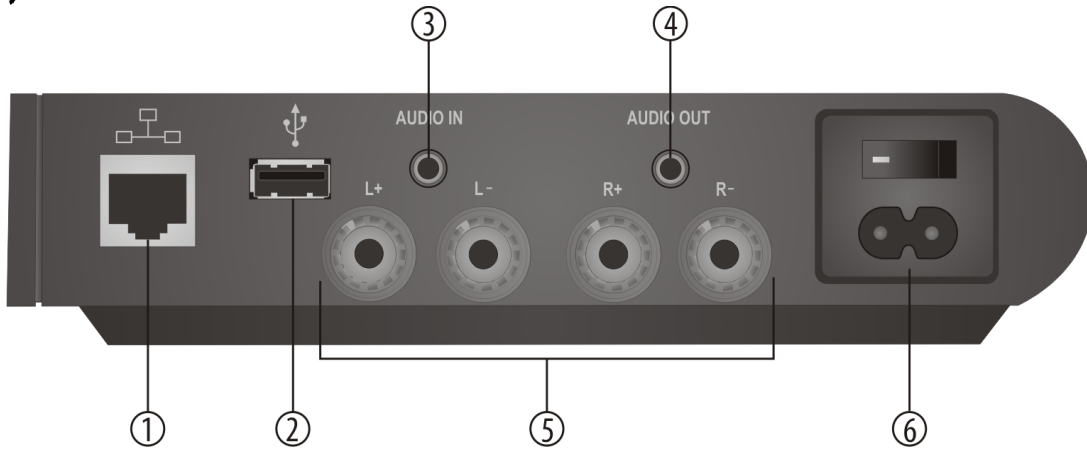

- 1. Ethernet:** This RJ45 port allows for a wired connection directly to the GW100 Gateway or directly to the network router.
- 2. USB:** Any USB compatible hard drive can share music content with the NuVo Wireless Audio System through this port.
- 3. Audio In:** This 3.5mm stereo input will accept any analog line level audio signal. The local audio source is amplified by the local player, as well as providing it as an additional source selection in any other associated audio zones within the NuVo Wireless Audio System.
- 4. Audio Out:** This 3.5mm stereo output provides the local line level audio signal to an additional amplifier, powered subwoofer, or headphones.
- 5. Left and Right Speaker Outputs:** These binding posts provide an amplified audio signal to any connected speakers. The maximum output of the P100 is 40 watts stereo.
- 6. AC:** The switchable universal power supply will accept any incoming AC voltage worldwide.

P200 Zone Player Back Panel Features

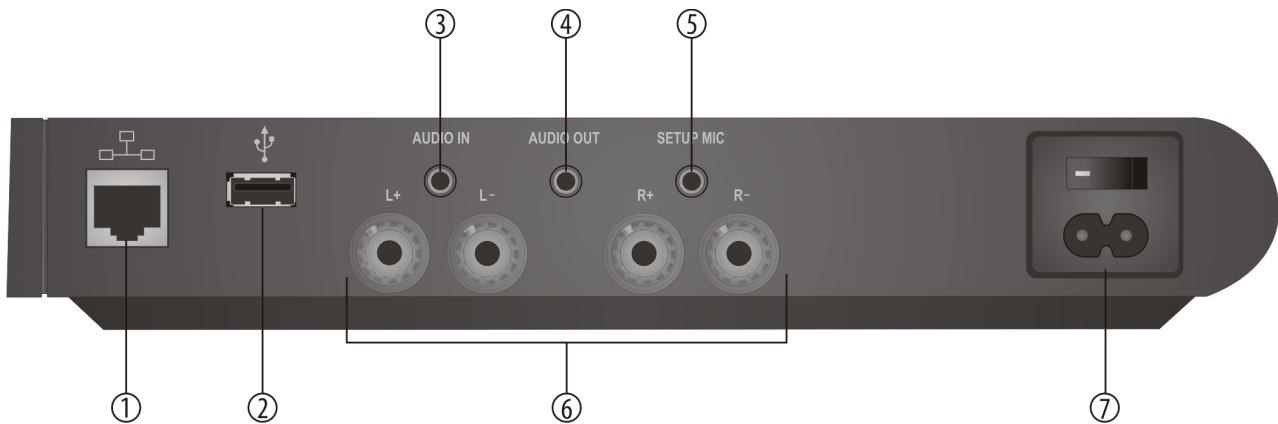

- 1. Ethernet:** This RJ45 port allows for a wired connection directly to the GW100 Gateway or directly to the network router.
- 2. USB:** Any USB compatible hard drive can share music content with the NuVo Wireless Audio System through this port.
- 3. Audio In:** This 3.5mm stereo input will accept any analog line level audio signal. The local audio source is amplified by the local Player, as well as providing it as an additional source selection in any other associated audio zones within the NuVo Wireless Audio System.
- 4. Audio Out:** This 3.5mm stereo output provides the local line level audio signal to an additional amplifier, powered subwoofer, or headphones.
- 5. Setup Mic:** This 3.5mm input is for future use with future software upgrades.
- 6. Left and Right Speaker Outputs:** These binding posts provide an amplified local audio signal to any connected speakers. The maximum output of the P200 is 120 watts stereo.
- 7. AC:** The switchable universal power supply will accept any incoming AC voltage worldwide.

P3100 Zone Player Back Panel Features



1. **Ethernet:** The P3100 is designed to connect directly to the network LAN. The second port enables multiple P3100s to share the same network connection within one system.
2. **Speaker:** This modular connection provides a maximum 40 watt stereo amplified signal to the connected speakers. Each zone represents an independent output.
3. **Line In:** This 3.5mm stereo input will accept any analog line level audio signal. The local audio source is amplified by the local Player, as well as providing it as an additional source selection in any other associated audio zones within the NuVo Wireless Audio System. Each zone represents an independent input.
4. **Line In Trigger:** This optional input is a 5 volt trigger. Each zone has an independent trigger used to turn the zone on with voltage from an external source.
5. **Line Out:** This 3.5mm stereo output provides the local line level audio signal to an additional amplifier, powered subwoofer, or headphones. Each zone represents an independent output.
6. **Line Out Trigger:** This 3.5mm output acts as a voltage (3-30V, 5mA) trigger for external equipment. Each zone has an independent output.
7. **USB:** Any USB enabled hard drive can share music content with the NuVo Wireless Audio System through this port. Each zone represents an independent input.
8. **Setup:** This button is used for each of the zone sections in the setup process to associate the zone control with the network.
9. **AC:** The switchable universal power supply will accept any incoming AC voltage worldwide.

1. Setup/Installation

1.1 Network Requirements

A live Internet connection is necessary for complete setup, operation, and music enjoyment of your NuVo Wireless Audio System. Once the system is set up and running, Internet is not necessary for listening to music streaming from a network source. A minimum 100mb wired network is necessary for proper communication. This should not be a problem. Today's network routers are designed to operate in the Gigabyte range. If this is not the case, you should update the installation's network equipment before you proceed with the setup. **The NuVo Wireless Audio System uses the most advanced dual band 802.11N wireless communication available for the most robust operation. To insure that all components are compatible and communicating correctly, it is strongly suggested network routers using the older 802.11G protocol are upgraded.**

1.2 Connecting the Gateway to the Network

The GW100 Gateway is the wireless communication point for the NuVo Wireless Audio System's players. It requires a standard Ethernet CAT5 or 6 (four twisted pair) wire connection to the home's network. It should be a standard EIA/TIA 568A or 568B network termination if you choose to terminate the cable to a specific length, as shown in fig. 1, or simply use a pre-terminated "network" cable (a cable is included in the package for this purpose), as shown in fig. 2. Note this is a straight-through connection. You should never connect the Gateway using a "crossover" style cable.

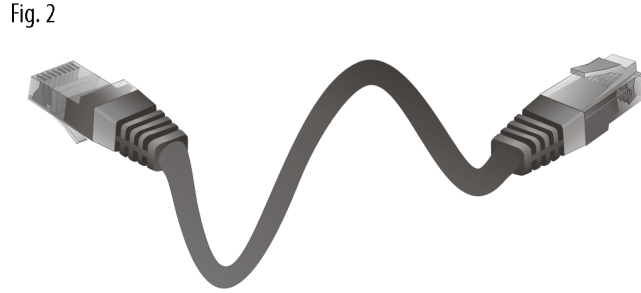
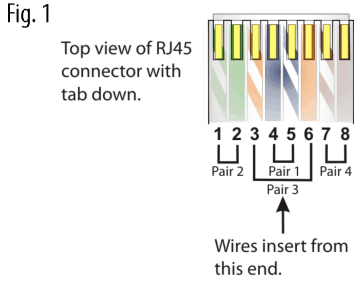
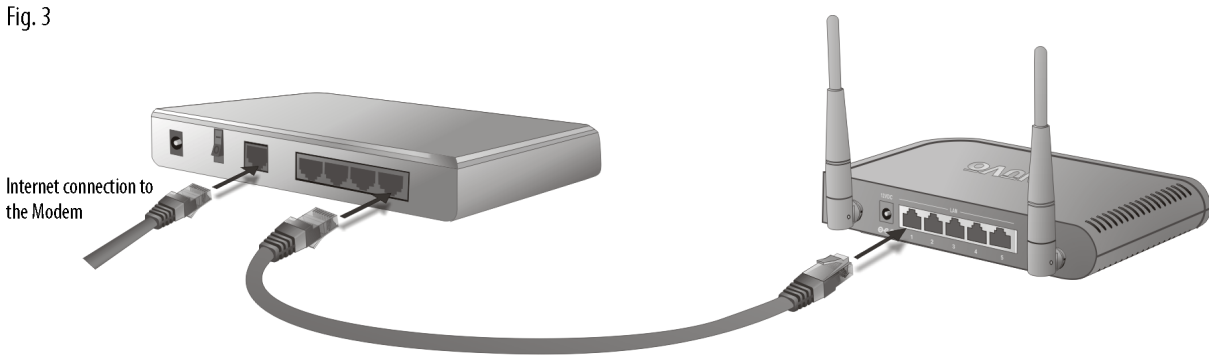

Fig. 1: EIA 568A and 568B wiring scheme for CAT5 Cable

Pin # 568A	Pin # 568B
1. Green Stripe	1. Orange Stripe
2. Green	2. Orange
3. Orange Stripe	3. Green Stripe
4. Blue	4. Blue
5. Blue Stripe	5. Blue Stripe
6. Orange	6. Green
7. Brown Stripe	7. Brown Stripe
8. Brown	8. Brown

Note: Colors listed as “stripe” are a white wire with a colored stripe.

Make sure that the installation’s router is connected to the network modem (this is generally supplied by the Internet Service Provider, ISP) with a single CAT5 network cable. The Gateway has five Ethernet ports and acts as a standard Ethernet switch. Simply connect the included cable, or any Ethernet cable with a standard RJ45 modular plug, into one of the five ports on the back of the Gateway and connect the other end into an available port on the back of the installation’s router, as shown in fig. 3.



A network switch can also be used for the connection to the Gateway, provided the switch is connected to the Internet through the network’s router. Once you have made the necessary connections, you are ready to continue with each audio zone setup.

1.3 Hardwiring the Players Directly to the Network

In lieu of running the players wirelessly, each P100 and P200 zone player has an individual Ethernet port. This port allows a standard four twisted pair wire, either CAT5 or CAT6, terminated with a modular RJ45 plug to “hardwire” the player directly to the system’s Gateway or network router, as shown in fig 4. Once the player is connected to the network via the Gateway or directly to the home’s router, the actual network connection will be completed from the control app on the desired control device, **see 2.2 Advanced Setup**.

Fig. 4

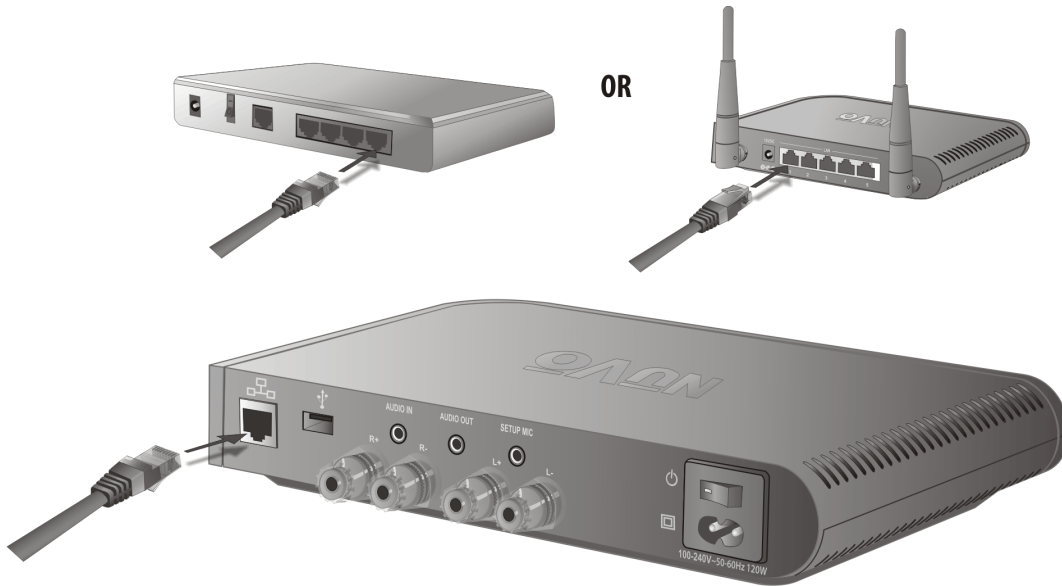

1.4 Installing the P3100 Zone Player

If you are installing the P3100 rack mount component, the network connection is completed by connecting one of the P3100's two Ethernet ports directly to the home's network using a standard Ethernet cable. Either of the two Ethernet ports will communicate when connected, as shown in fig. 5. The second port is used for daisy chaining multiple P3100 units for more audio zones, as shown in fig. 6. **Note that the P3100 is not a wireless device and does not use the Gateway for communication.**

Fig. 5

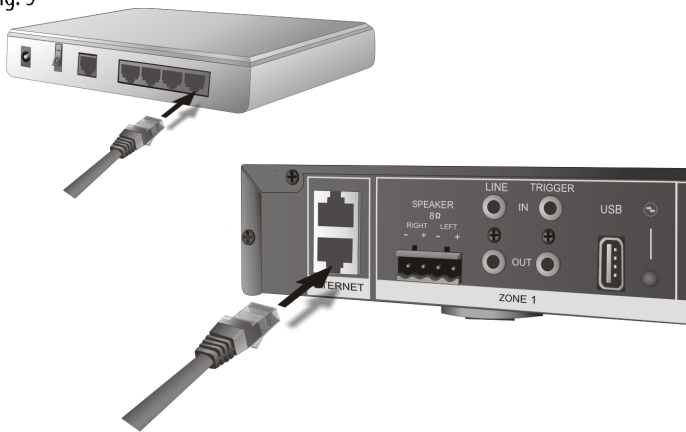
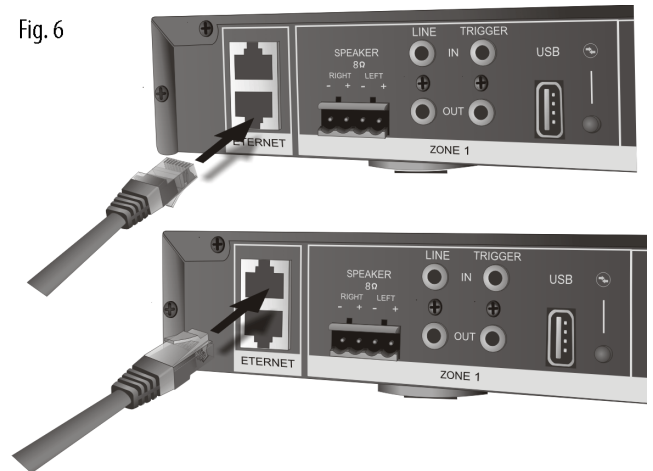

Fig. 6



1.5 Connecting Speakers to the P100 and P200 Zone Players

The P100 and P200 zone players are equipped with “5-way” binding posts for connecting the amplified audio signal to speakers. These can be bookshelf, floor standing, or installed in the wall or ceiling. 16 gauge speaker wire is recommended for this purpose. The binding posts provide two different methods for terminating the wire. The post can be unscrewed to expose a hole for the speaker wire. Strip about 1/4 inch of insulation from the inner conductor wire and insert it into the hole. Screw the post back in until it firmly secures the wire, as shown in fig 7. The alternative method is to terminate the speaker wire into “banana” plugs and insert that into the end of the binding posts, as shown in fig. 8. **Be careful to keep the positive and negative speaker connections consistent at both ends. Crossing the left and right terminations will inhibit the audio quality from the amplifier.**

Fig. 7

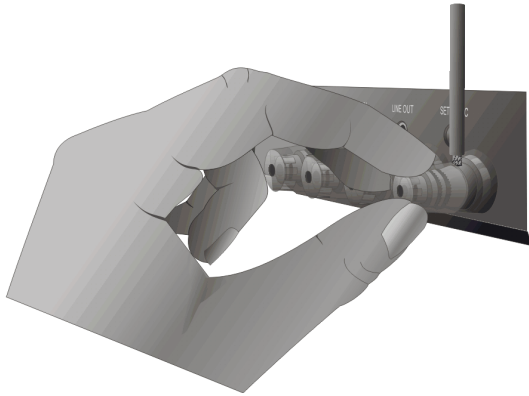

Fig. 8



1.6 Connecting Speakers to the P3100 Zone Player

The P3100 zone player has three separate zone “euro” style speaker connectors. The speaker wire is terminated into this modular plug and then inserted into the appropriate zone output on the back panel of the P3100, as shown in fig. 9. **It is only necessary to strip about 1/8 inch of the insulation from the inner conductor for these plugs. Be careful not to let the exposed speaker wires touch. This will short the connection and could damage the amplifier.**

Fig. 9

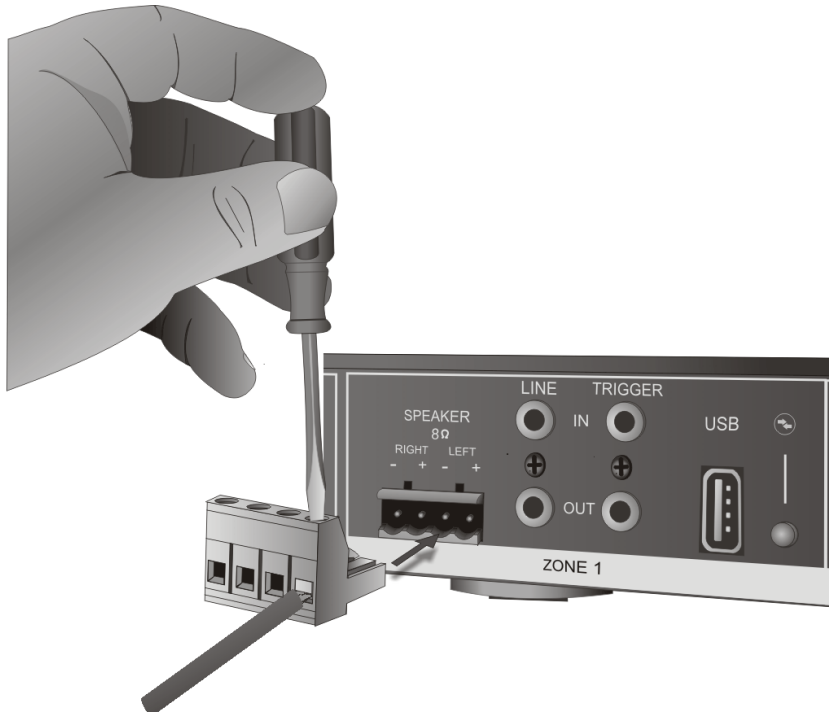

2. Setting Up a System from the iOS or Android App

Once you have connected the system to the local network you are ready to begin adding zone players in their desired locations, naming those locations for local control and creating your multi-zone music system. The process is easily done from any iPod Touch, iPhone, iPad, or Android device using the NuVo Wireless Audio System app.

2.1 New Wireless System Setup

Download the app to your device from the iTunes App Store or the Google Play Marketplace. Make sure your device is connected to the same network as the NuVo Wireless Audio System. Open the app and select "Setup a new system" from the initial screen. "Join my existing system" is used to connect a new iOS or Android device to an existing system, as shown in fig. 10. **Note that the iOS app will not run on older iOS devices that cannot support iOS5 or later versions.**

Fig. 10



You should already have connected your Gateway to the home's network. If not, make sure that connection is made, **see section 1.2, Connecting the Gateway to the Network**. When the Gateway and home router connection is made, simply touch "Next", as shown in fig. 11.

Fig. 11



Fig. 12



The app will indicate that the Gateway is connected to the network. Touch "Next" to proceed to the individual zone player setup, as shown in fig. 12.

The next step is to place your first zone player in its desired location. When it is plugged in and powered on, the front LED light will flash white while the player is booting up. When it is ready the front panel LED will be solid green. Touch the “Next” button to proceed to the next step, as shown in fig. 13.

Fig. 13

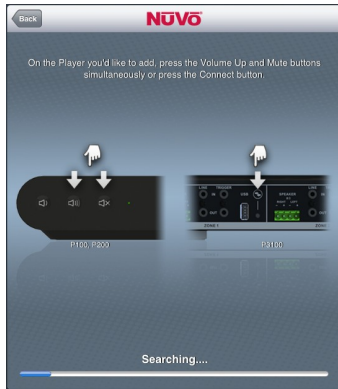

Each player is assigned a network ID as well as a NuVo System ID. This process is completed by pressing the Volume UP and Mute buttons on the front panel of the P100 and P200 players simultaneously, or press the Zone Setup button located on the back panel of the P3100 player, as shown in fig. 14. Note that the P3100 represents three individual zones in the system. Each zone output section has its own setup button, requiring the process to be repeated on each

Fig. 14

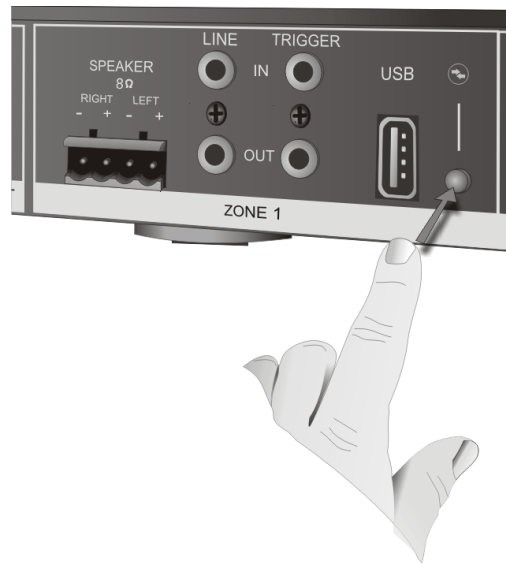

Fig. 15



While the connection is being made, the front panel LED will flash. The app will indicate when the connection is complete and the LED will be solid white. Touch "Next" to proceed, as shown in fig. 15.

Fig. 16



Choose a zone icon for the player. You can use the "Edit Name" button to give the zone a customized name. When the selection is complete, touch the "Done" button, as shown in fig. 16.

Fig. 17

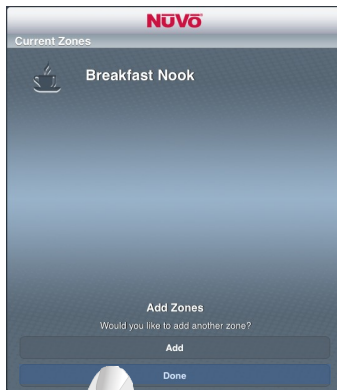

The "Add" button will repeat the setup process for the next zone. If you have completed the setup on all of the desired zones, touch the "Done" button. The app will go to the home screen, referred to as the Dashboard view, as shown in fig. 17. From there any zone can be selected for music playback, and you are ready to enjoy music anywhere in the home, as shown in fig. 18.

Fig. 18

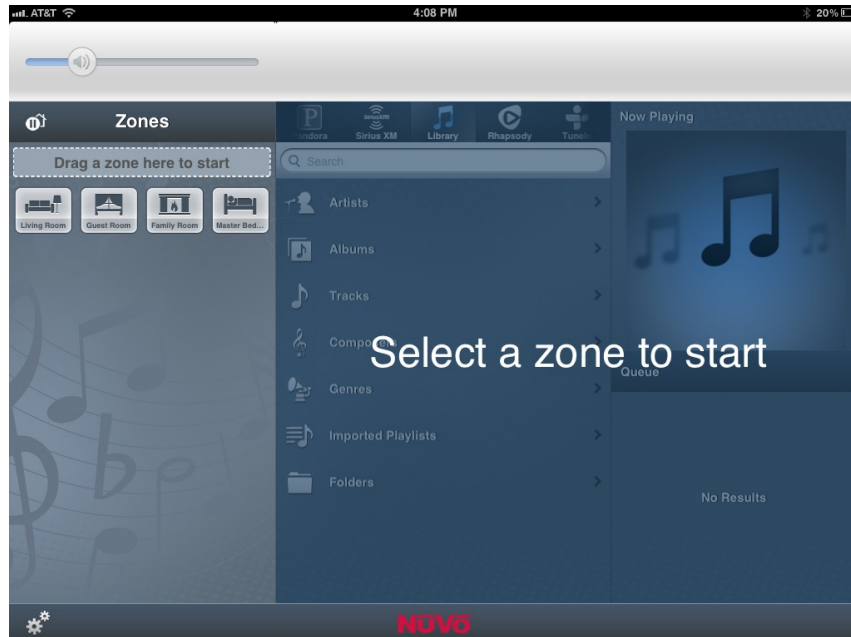

Select a zone to start

2.2 Adding Zones to an Existing System

Once a system is set up, adding additional P100, P200, or P3100 zone players is easily done.

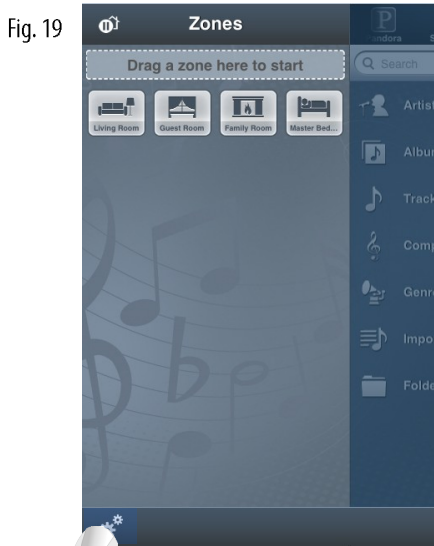

To do this, go to the “Settings” button at the bottom of the Dashboard, which is the section of the app defined by the zone icons, as shown in fig. 19.



Touch the “Add a NuVo Component” button. This will take you to the same zone setup procedure, as shown in fig. 20.

From this point the setup is identical to the process covered in section 2.1, **New System Setup**.

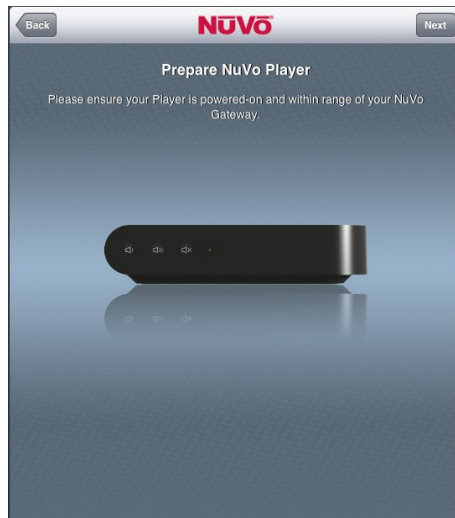

2.3 Adding Additional Gateways to an Existing System

Up to two additional Gateways can be added to a system when additional Wi-Fi range is needed. Additional Gateways must be hardwired to the network along with the original Gateway. This can be done by plugging the new Gateway(s) into the first Gateway, into the installation's router, or a switch from the router. When a new Gateway is added to the system, go to the Settings menu and select "Add a NuVo Component", as shown in fig. 21. The Controller will recognize that a new Gateway has been added and the next step is to touch "Add Gateway(s)", as shown in fig. 22.

Fig. 21



Fig. 22



The next step will join the new Gateway to the system, as shown in fig. 23. When the process is complete, the app will indicate that the Gateway has been successfully added, as shown in fig. 24.

Fig. 23



Fig. 24



The zones in the system will automatically connect to the best Gateway signal, depending on their location.

3. Using the iOS and Android Control App

The iOS and Android apps offer complete system control wirelessly from any Wi-Fi enabled phone or tablet. The iOS version is available for free download from the iTunes App Store and the Android version is available from Google Play. Both versions offer the same look and control options. The iPad version is nicely optimized for a view of the complete system operation on one screen.

3.1 The Dashboard

System control begins with the Dashboard. All of the available zones are represented by an icon. Your initial selection is done by dragging and dropping a zone into a new zone group, as shown in fig. 25. This can also be done by simply tapping an inactive zone. Once a music selection is made, the related album art and now playing information will appear in the zone group. Zones can play music individually or you can share music by dragging and dropping multiple zones into a single group, as shown in fig. 26.

Fig. 25



Fig. 26



To deactivate a zone and stop the music playback, simply drag the icon back into the open dashboard area below the zone groups.

3.2 Music Selection

When a zone group is activated, the app will go to the music navigation pane. From there, any streaming service, personal music libraries, Bluetooth, or local line in sources can be selected for playback. The available music choices are visible in a music selection ribbon. As you scroll across the selections with your finger, the active choice will be highlighted and the display will change accordingly, as shown in figs. 27, 28, and 29.

Fig. 27

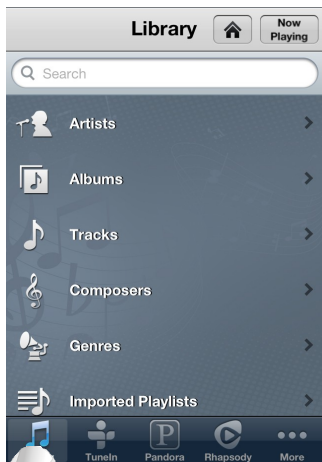

Fig. 28

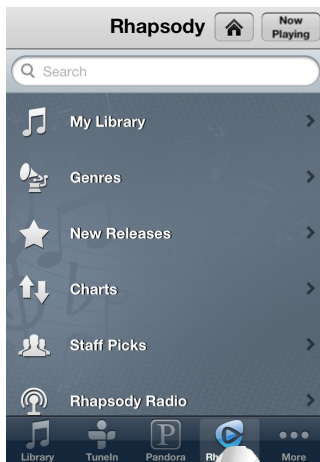
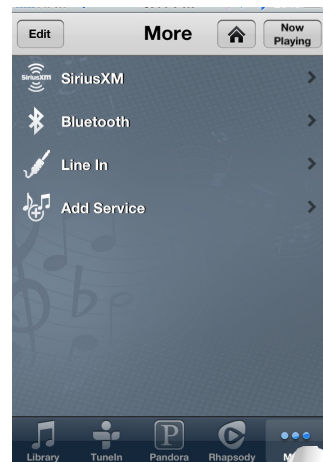

Fig. 29



3.3 Bluetooth® Playback

An important feature of the P200 zone player is the ability to stream music content from any Bluetooth enabled device.

To take advantage of Bluetooth streaming, make sure that your device's Bluetooth is turned on. This is done within the device's settings. When in range of a P200, that zone will appear in the device's Bluetooth menu. Choose the zone to "pair" your device. Note that the iOS app will immediately connect, as shown in fig 30. Android devices will show the selection as paired, but not yet connected.



A paired device will remain paired and available when it is within range of the paired zone. To connect a device and initiate playback, select Bluetooth as an audio source, as shown in fig. 31. Then select the desired device, as shown in fig. 32. The app will show the selected device as "Connected", as shown in fig. 33, and the zone player will switch to the Bluetooth stream. Music content control is made from the connected device.



3.4 Line In

Each player has a 3.5 inch stereo audio line in on its back panel. This input allows any local zone analog music source to be plugged in and added to the system as an additional source input. This is done by connecting a 3.5 mm stereo audio cable from the audio output on the playback device and into the input on the zone player, as shown in fig. 34.

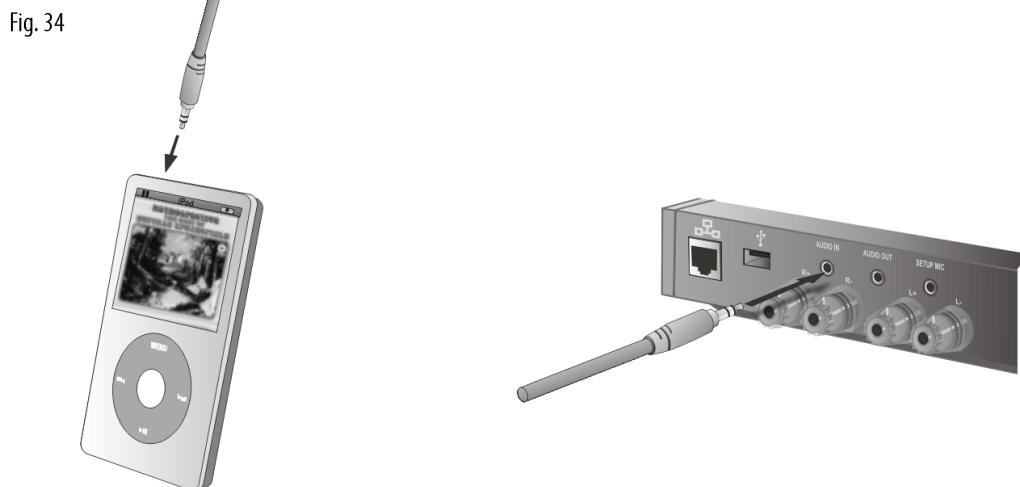

When a line in device is connected in a zone, select “Line In” from the app, as shown in fig. 35. The device will appear in the “Line In” menu and be available for selection from all the zones, as shown in fig. 36. If the line in source is intended to be permanent, a specific name can be given to it in the app, as shown in figs. 37 and 38.

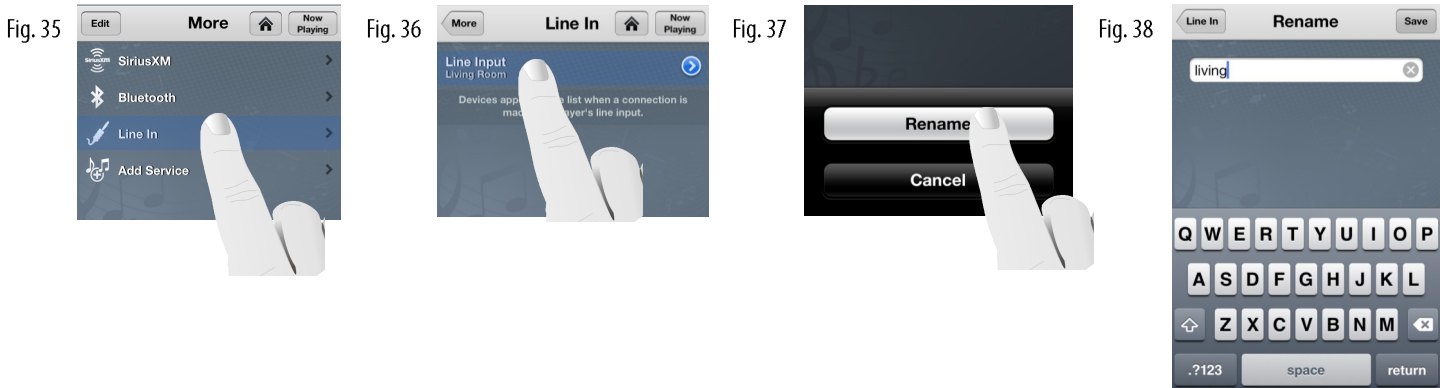

4. The Settings Menu

The Settings menu has several selections important to the system’s control and operation. Access to Settings is made through the “Settings” button located at the bottom of the Dashboard. On the smaller format devices such as the iPhone, iPod Touch, or Android phones. If you are on the “Now Playing” screen or browsing musical selections, the “Home” button at the top of the screen will always return the app to the Dashboard, as shown in fig. 39. From there, touch the “Settings” button, as shown in fig. 40 to access the Settings menu, as shown in fig. 41.

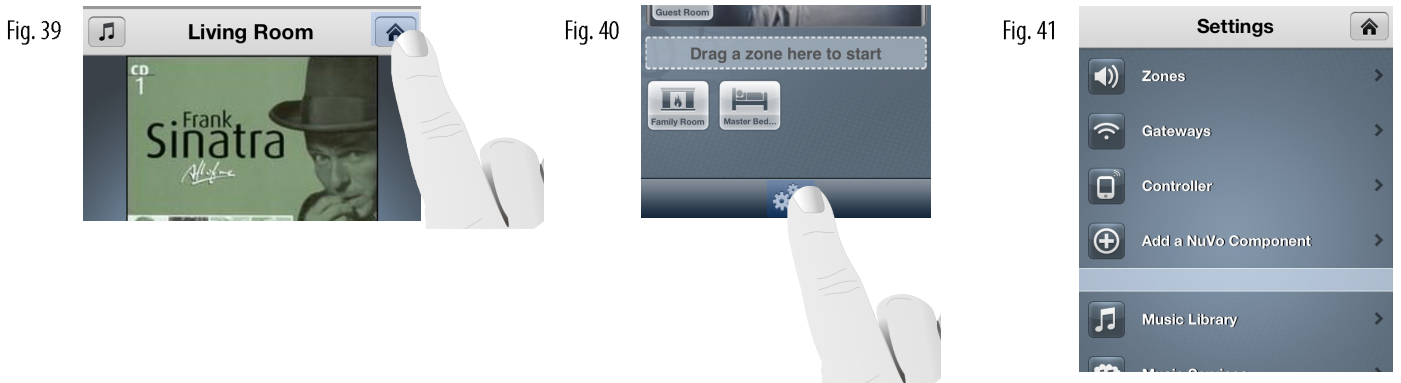

4.1 Zones

Selecting “Zones” in the Settings menu provides several controls for audio playback and functionality, as shown in fig. 42. When the “Zones” button is touched, the app will display the choice of zones within the system, as shown in fig. 43. When one of the zones is selected, its individual settings and controls will be available, as shown in fig. 44.



The Zone Settings menu has several zone playback choices that are simple slider adjustments or on/off choices.

Bass, Treble, and Balance: These three sliders allow individual settings for each zone.

Loudness: This on/off button allows for bass boost designed for low volume listening.

Fixed Volume Line-Out: Each of the zone players have an individual audio line out. This allows the audio output of the zone to be supplied to an additional amplifier, sub-woofer, or even headphones. By default, the volume level of this output will adjust with the volume setting made on the app. In some uses, such as a separate amplifier being used in a sub-zone, a fixed volume level that requires a separate volume control is preferred. For those instances, turn this feature on.

Mono: When this feature is turned on, it sums the individual left and right stereo outputs into a single identical audio output for each of the speaker terminals. This is a very useful feature in allowing a single mono speaker to provide all the stereo audio content to a zone, or you may have a large zone in which the speakers would be too far apart to be in ear-shot of a single listener.

Audyssey Dynamic Volume: This is designed to level relative volume between audio selections. This feature is useful where the music is meant to be at a lower background level. It is not recommended for critical listening scenarios.

If you touch the zone icon and name at the top of the “Zones Settings” screen, the zone icon page will appear, as shown in fig. 45. From there you can change a zone icon and name, as shown in fig. 46.



The “Advanced” button has a single selection, as shown in fig. 47. It allows the P100s and P200s wireless communication to be set at the default 2.4 GHz band or the higher 5 GHz, shown in fig. 48. In most settings 2.4 is preferred. The exception is a scenario in which there are many wireless networks operating in close proximity. Since most network traffic is in the 2.4 GHz band, audio streaming could be a challenge. In these instances, the zone can be changed to 5 GHz where there is more streaming bandwidth and the traffic is much lower. **Note that the 5 GHz wireless range is lower than 2.4. Multiple Gateways can be installed to increase the wireless range when needed, see section 2.3 Adding Additional Gateways to an Existing System.**

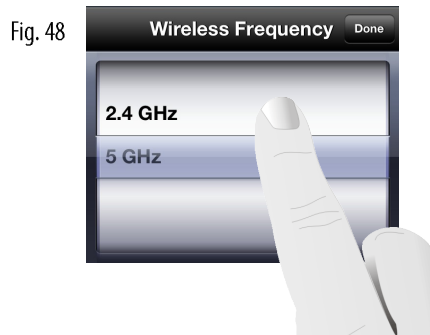
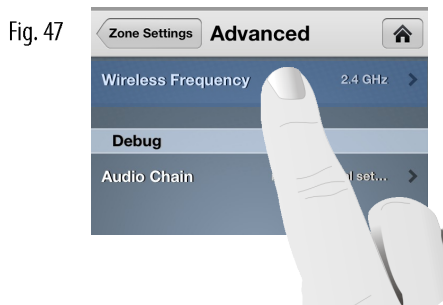

When this setting is changed, the P100 or P200 will go offline momentarily causing the front panel LED to flash red. When the LED returns to solid white, the zone is back on the network and ready to resume normal operation. **This wireless band selection only applies to the P100 and P200 wireless players. This feature will not be active if you are using the P3100.**

4.2 Gateways

The Gateway selection allows you to view and change important settings to the Gateway(s) operation. When “Gateways” is selected, the app will show the Gateways present in the system, as shown in fig. 49. The Gateway page will show “Name”, “Serial Number”, and “Wireless”, as shown in fig. 50.



When “Name” is selected, a screen with a keyboard will allow the name of the chosen Gateway to be edited, as shown in fig. 51. This is useful if you are using more than one Gateway in a system. “Wireless” shows the current channel selection for 2.4 and 5 GHz broadcast, as shown in fig. 52. The default is “Autoselect” but when that feature is turned off, a manual channel select choice will appear, as shown in fig. 53.

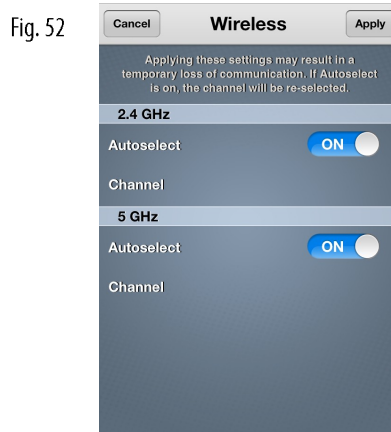

4.3 Controller

When “Controller” is selected, as shown in fig. 54, a page will appear with the current software version number, as shown in fig. 55. It also has a “Reset” button which will disassociate the app from the system. The screen will display its original preconfigured state, as shown in fig. 56.

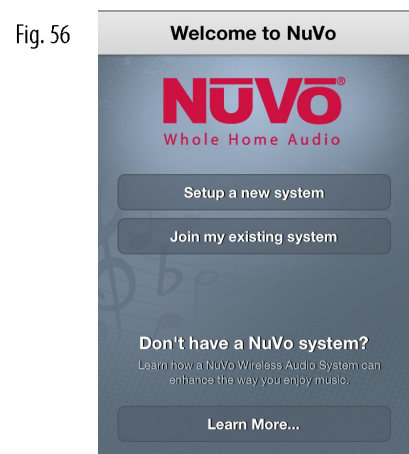
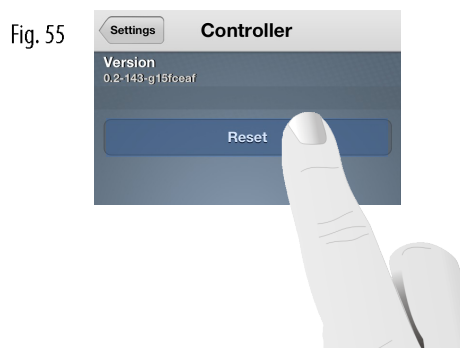

4.4 Add a NuVo Component

See section 2.2, Adding Zones to an Existing System.

4.5 Music Library

Existing personal music is easily shared with the entire system by plugging a USB hard drive into the USB port on the back panel of any of the zone players, as shown in fig. 57. The player will automatically scan the drives content and add it with its associated album art to the system’s music library.

Fig. 57

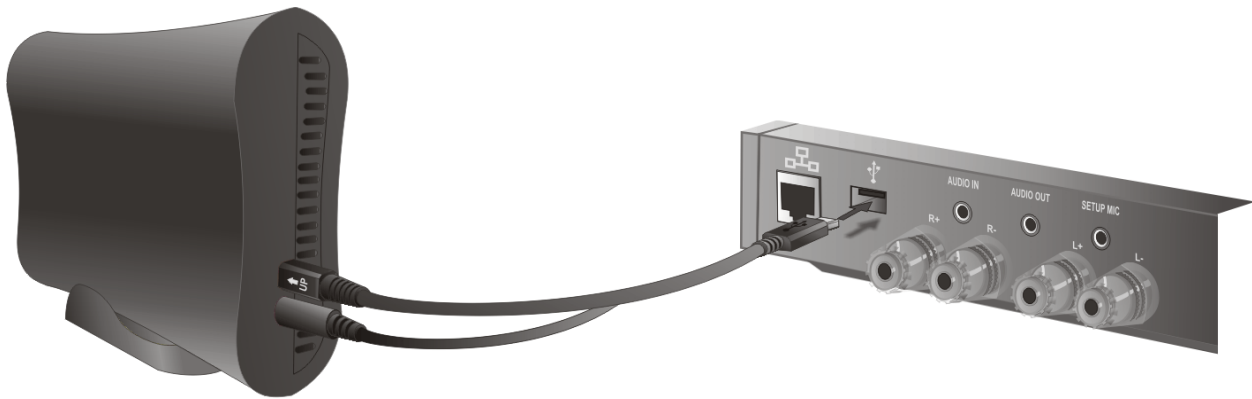

Another way to add music is to use the Music Share software, **see section 5, The Music Share Software**. Once music is added and you select “Music Library”, as shown in fig. 58, the Music Library screen will display the number of songs and file size of the accumulated library, as shown in fig. 59. It will also show the individual sources for music content. An additional selection “Add Share” will allow you to type in the network path to a directory or shared drive with music content, as shown in fig. 60. When a new library is added, it may take time for the content to be refreshed. The length of time depends on the amount of content.

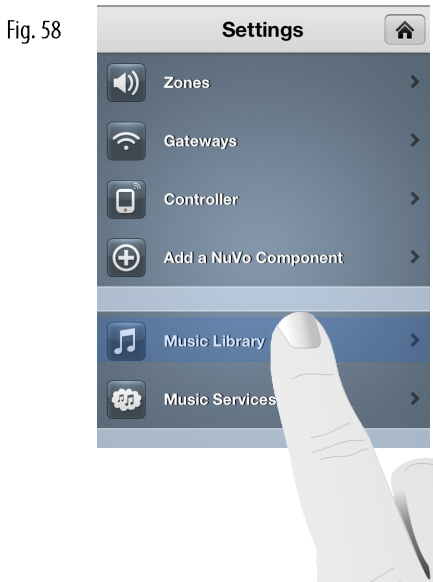

New music shares will appear in the music library as “Refreshing” while the files of the library are scanned. Once the refresh is completed, the content will be available for browsing and playback.

4.6 Music Services

When “Music Services” is selected, as shown in fig. 61, the active streaming music services on the system will be displayed, as shown in fig. 62. It also provides a button for adding new services. Most services require an online subscription account. The associated user name and password for the account must be added in this selection for the service to be active on the system.

Fig. 61

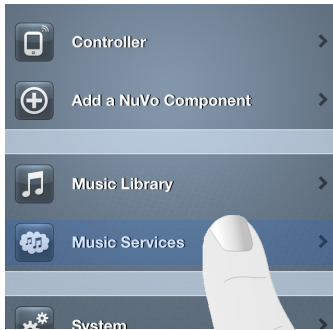
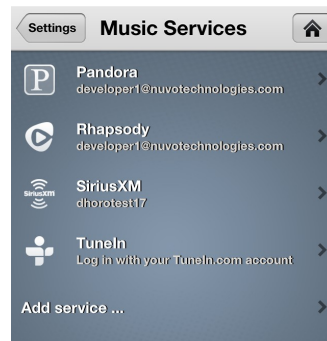

Fig. 62



Note that music service availability is based on your region. The cost, functionality, and terms of subscription vary by service.

4.7 System

When “System” is selected, as shown in fig. 63, the menu will display three important choices for information about the components of the system, as shown in fig. 64. The first choice, “About”, gives specific component information for each zone, as shown in fig. 65.

Fig. 63

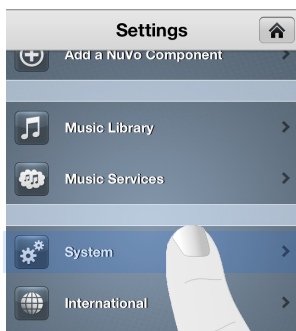
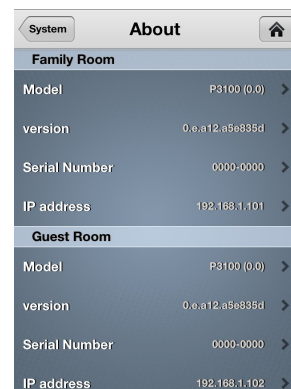

Fig. 64



Fig. 65



“Software Update” will show any software updates that may be available, and allow for easy updates, as shown in figs. 66 and 67.

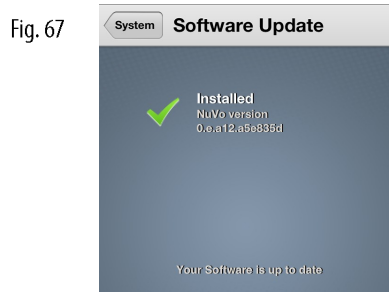

“Registration” will open the product warranty registration page, as shown in figs. 68 and 69. The opportunity to register the product is offered at the initial setup of the system. If the registration is completed at that time, this System selection is not necessary.

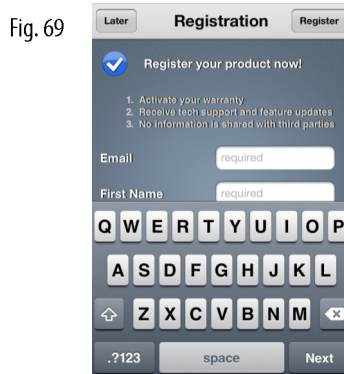

4.8 International

The “International” selection, as shown in fig. 70, provides a “Location” setting, as shown in fig. 71. When a country location is set, as shown in fig. 72, the legal 5 GHz wireless broadcast channel is set for the selected region. This is an important selection if you are using the 5 GHz wireless band for communication, **see section 4.1 Zones “Advanced”**.

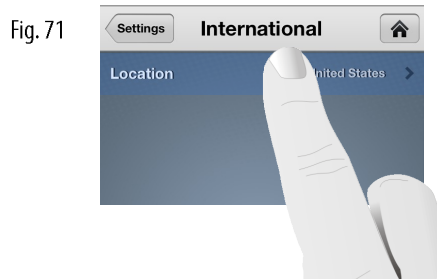
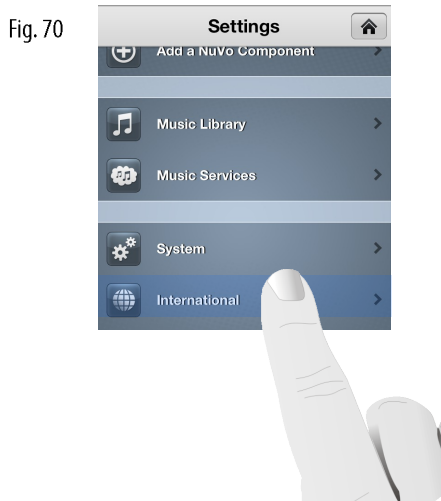

4.10 Help

The “Help” button, as shown in fig. 73, has links to contact NuVo directly or reference information on the system’s components, as shown in fig. 74.

Fig. 73

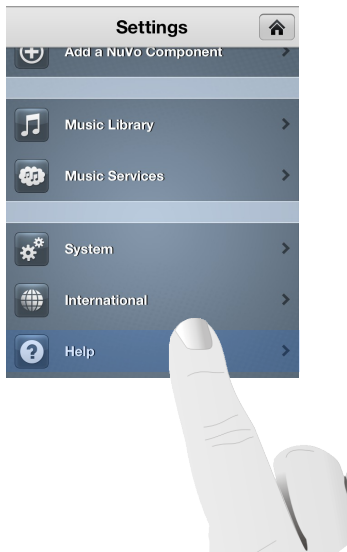
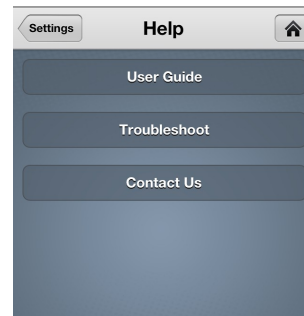

Fig. 74



5. The Music Share Software

The Music Share Software allows music content from either shared network locations or libraries contained on personal computers to be streamed from any zone in the system.

1. From your computer, go to www.nuvotechnologies.com/music share to download the software from the NuVo website.
2. Follow the prompts for installing the software.
3. When the software is opened, it will connect to the network and display a blank music share page, as shown in fig. 75.

Fig. 75

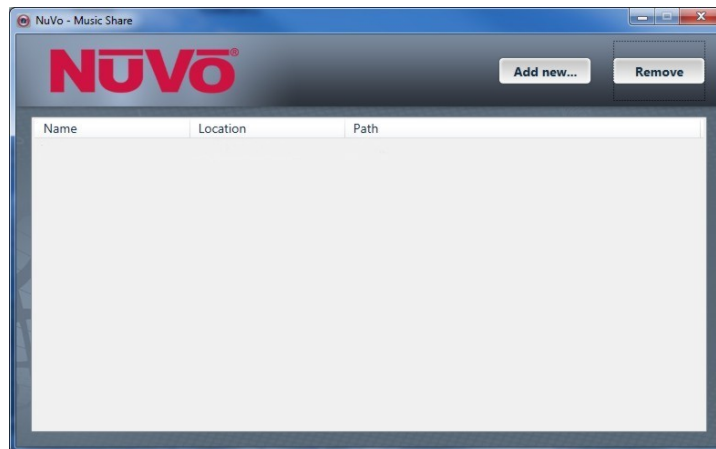

- Click on the “Add new” button at the top of the window. The music share choices will open in the next window, as shown in fig. 76. “My Music” folder is the default location for Windows Media Player libraries. If your music is stored on a Mac computer, or your preferred music library software is in iTunes, then select “iTunes media folder”. When a selection is made, you will see a progress window, as shown in fig. 77.

Fig. 76

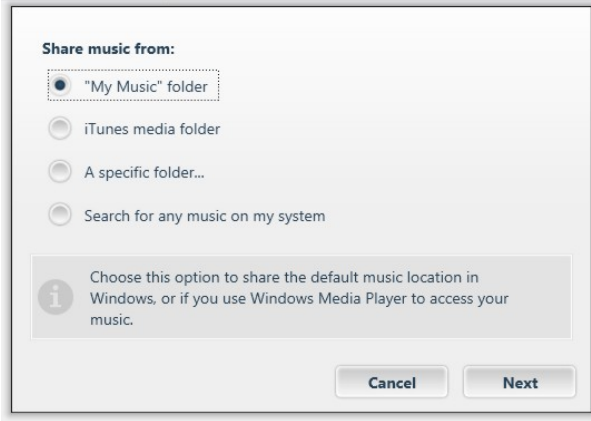
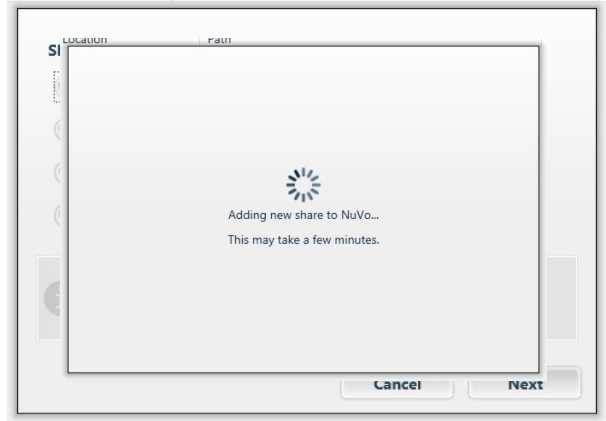
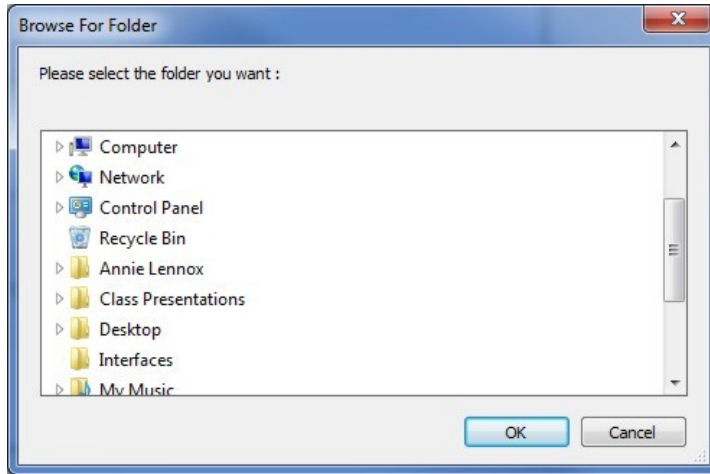

Fig. 77



- You can also choose to share a specific folder or drive on the network. The “A specific folder . . .” choice will open Windows Explorer, as shown in fig. 78. From there you can choose a shared folder with music content or drive that is shared with the network.

Fig. 78



- All shared folders and drives will be displayed in the software, as shown in fig. 79. The software can be opened at any time and content can be added or removed.



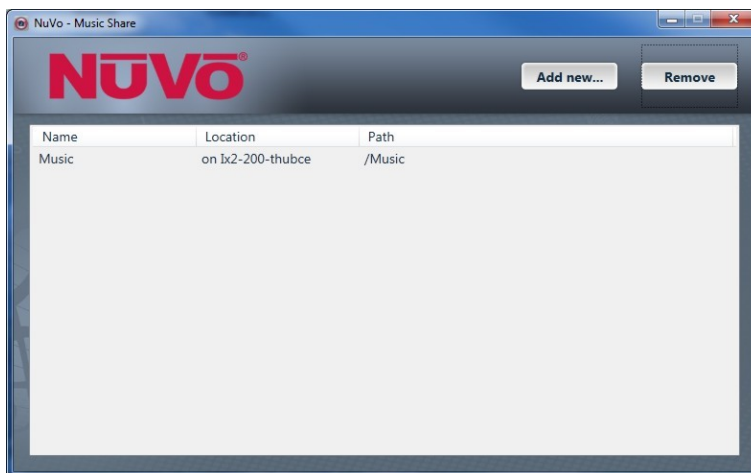







Fig. 79



6. Troubleshooting

6.1 Front Panel LEDs

An important indicator of each zone’s operation is the LED light on the front panel of the zone players. The color and either solid or flashing state of the LED provides a visual reference for the player’s state of operation. Refer to the chart for an explanation of the functions and LED status.

LED Color	State of Zone Player	Explanation
	Not Lit	Zone player is not powered on.
	Solid White	Zone player is connected to the network and in normal operation.
	Flashing White	Zone player processor is busy; it should return to solid white.
	Solid Red	Hard failure. There is no network communication. Reboot by turning the power off and back on.
	Flashing Red	If the LED is flashing Red, its state indicates that the zone player is no longer seeing the network.
	Solid Green	Uninitialized state. It will become solid white when the zone player acquires a network address and is connected to the network.
	Flashing Green	Busy uninitialized state. This is normal during the zone setup process. The LED will turn white at the completion of the zone setup.
	Solid Cyan	Zone is muted. When it is taken out of mute, it will return to solid white.
	Flashing Blue	This indicates that the P200 is in Bluetooth discovery mode.
	Flashing Green	Zone is updating to a new version. Do not unplug during this process. At the completion of the update it will return to solid white.

6.2 Not Connected

A common indicator for lack of communication with the system is the app’s “Not Connected” screen, as shown in fig. 80. This screen appears when the controller is unable to see the zones in the system. There are several potential causes and remedies for this state that are important for troubleshooting.

Fig. 80

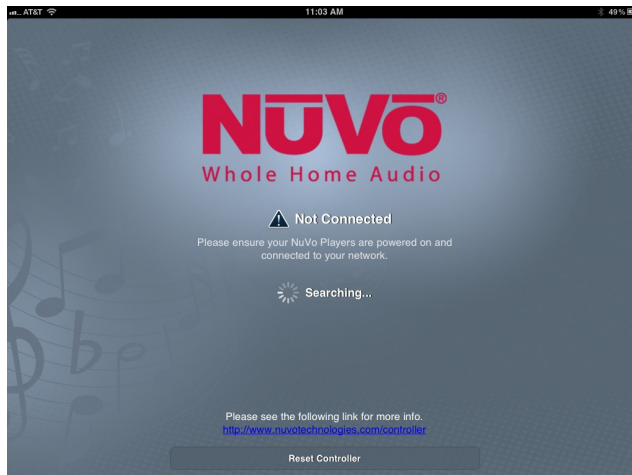

1. Look in the network settings of your control device and verify that it is connected to the same network as the Gateway and zone players.
2. This may sound relatively simple, but check the power status of the zone players. They should have a solid white or cyan LED light on the front panel.
3. Make sure that one or more of the players are not offline. This state would be indicated by a flashing red LED on the front panel. This can occur as a momentary state, in which case the LED will return to a solid white when the network connection is restored. This is often corrected by simply turning off and restoring power to the player. Once it is rebooted it should have a solid white LED on the front panel. If that does not restore a connection, reset the player defaults by turning the power off and back on. When the front panel LED lights up, touch the Volume Down and Volume Up buttons simultaneously until you see a flashing green LED. When the reset is complete, the LED will be a solid amber color. Repeat the zone player setup procedure from the control app, **see section 2.2 Adding Zones to an Existing System**. When the zone is reconnected the front panel LED should once again be solid white.
4. If you are using a Gateway, check its connection to the network's router. Reboot if necessary by unplugging the power cable and plugging it back in. This resets the Gateway and puts it back into channel auto select. If there is conflicting traffic on a given Wi-Fi channel, this will often correct the situation.
5. Occasionally home routers go offline. This is typically corrected by rebooting the router.

6.3 Restoring Defaults

An important troubleshooting step is to restore defaults on a zone player. If a hard failure occurs, which results in a solid red LED, or the boot up process does not complete correctly, which will result in a flashing white LED, you should follow these steps to return the player to its original factory state. Once a zone is reset, repeat the setup procedure from the control app.

Process for the P100 and P200 wireless players:

1. Turn off the power using the power switch on the back panel above the AC plug.
2. Turn the power back on and look for a white LED to light up.
3. As soon as you see a white LED, touch the Volume UP and Volume down buttons simultaneously, as shown in fig. 81.
4. When the LED appears green, release the buttons.
5. The LED will flash green, then white.
6. When the LED becomes solid green, the process is complete and the defaults have been restored.

Fig. 81

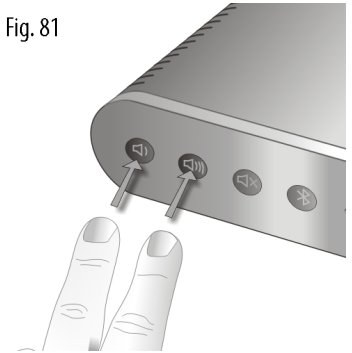

Process for the P3100 players (these steps must be performed on each zone output independently):

1. Turn off the power using the power switch on the back panel above the AC plug.
2. Turn the power back on and look for a white LED to light up.
3. As soon as you see a white LED, touch the zone setup button, as shown in fig. 82.
4. When the LED appears green, release the button.
5. The LED will flash green, then white.
6. When the LED becomes solid green, the process is complete and the defaults have been restored.

Fig. 82

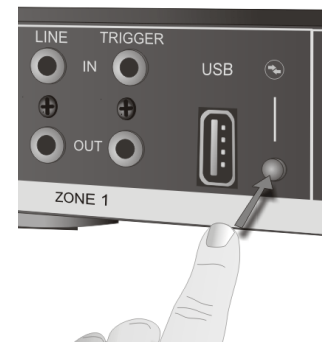

6.4 Advanced Network Management

A popular practice is to prioritize home network traffic by creating VLANs (Virtual Local Area Networks) to provide better performance for streaming audio and video. This work should only be done by a network administrator. The practice uses configurable network switches that allow specific ports to be grouped for their specific VLAN communication. Each of the VLANs are considered broadcast domains. The concept of broadcast domains is very important to proper communication among the components of the NuVo Wireless Audio System. For all zones to communicate properly they must be on the same broadcast domain. Make sure that the switch ports being used for the NuVo Wireless Audio System are operating on the same VLAN.

Another potential issue with zone communication can be the way in which port security has been configured. Since the components of the system are continually sending packets of information back and forth, it is important that the switch ports being used are open to all network traffic. If they are not, this will impede the necessary communication across the entire system.

On any managed switch, speed and duplex must be set on the ports being used by the NuVo Wireless Audio System to auto negotiate. This is the way in which the zones communicate. The common mistake would be to set the ports to gigabit communication which will cause a communication mismatch with the zones.

For more advanced troubleshooting, please visit www.nuvotechnologies.com/troubleshooting/player.

7. Specifications

GW100 Gateway

System Information

LAN Connection	5 LAN - RJ45 - 10/100/1000 Mbps
Wireless Connection	2 TX x 2 RX MIMO, IEEE 802.11a/b/g/n Dual Band – Concurrent
Wireless Data Rate	Up to 300 Mbps

Power Requirements

Power Supply	12V DC, 1.0A
Input Voltage	100 – 240VAC, 50/60 Hz
Rated Power	12W

Regulatory Approvals

Controller	FCC, IC, CE-EMC, C-Tick
EMC	
Power Supply	
Safety	cULus, GS Mark, CE-LVD
EMC	FCC, IC, CE-EMC, C-Tick
Environmental Compliance Europe	RoHS

Operating Temperature

0 °C to 40 °C

Physical Specifications

Unit Size (mm)	32.8 H x 176.5 W x 133 D (including antennas)
Unit Size (inch)	1.29 H x 6.95 W x 5.24 D (including antennas)
Unit Weight (kg)	0.55
Unit Weight (pounds)	1.21

Shipping Specifications

Unit Size (mm)	240 D x 230 W x 65.5 H
Unit Size (inch)	9.45 D x 9.06 W x 2.58 H
Unit Weight (kg)	0.90
Unit Weight (pounds)	1.98

NuVo reserves the right to change specifications without notice.

P100 Wireless Player

Input/Output Connectors

Line Input	1 - TRS 3.5 mm stereo jack
Line Output	1 - TRS 3.5 mm stereo jack
Speaker Output	4 - Gold 5-way binding post
USB 2.0 Connection (Type A)	1
Local Area Network (LAN)	1 - RJ45

Supported Audio Formats

Music File (USB or over network)	MP3
	WMA
	AAC
	Ogg Vorbis
	FLAC
	WAV

Internet Radio

Pandora
Sirius/XM
Rhapsody
Tuneln

IP Control

Apple iTunes®
Apple iPhone®
Apple iPad®
Android Mobile
Android Tablet

Network Connectivity

LAN (Wired Connection)	10/100base-t Ethernet
Wireless Connection	MIMO, 2 TX + 2 RX Channels IEEE 802.11a/b/g/n

Amplifier Output

Rated Output Power (8 ohm)	40W (20W x 2)
Two channels driven 20 Hz – 20 KHz @ 0.5% distortion	
Rated Distortion (1/2 Power)	0.20%
Speaker Impedance	6 – 8 ohms
Frequency Response (20-20kHz)	+/-0.5 dB
Damping Factor	50+
Signal-to-Noise Ratio, rated output:	94 dB A – weighted

Line Output

Output Level	0-1000 mV RMS
Output Impedance	5 Ohms
Signal-to-Noise Ratio, rated output	88 dB A – weighted

Line Input

Input Impedance	10 KOhms
Input Overload	2.3 V RMS

Audio Processing

Audyssey Dynamic Volume™	
Bass Equalization	+/-12 dB range
Treble Equalization	+/-12 dB range
Balance	

Regulatory Approvals

Safety:	cTUVus, CE-LVD
EMC:	FCC, IC, CE-EMC, C-Tick
Environmental Compliance Europe	RoHS

Power Requirements

Input Voltage:	100 – 240VAC, 50/60 Hz
Power Consumption (max):	70 W
Power Consumption (typical – 1/8 audio power):	13 W

Operating Temperature

0 °C to 40 °C

Physical Specifications

Unit Size (mm)	42 H x 187 W x 115 D
Unit Size (inch)	1.65 H x 7.36 W x 4.53 D
Unit Weight (kg)	0.613
Unit Weight (pounds)	1.35

Shipping Specifications

Unit Size (mm)	240 D x 230 W x 65.5 H
Unit Size (inch)	9.45 D x 9.06 W x 2.58 H
Unit Weight (kg)	1.30
Unit Weight (pounds)	2.87

NuVo reserves the right to change specifications without notice.

P200 Wireless Player

Input/Output Connectors

Line Input	1 - TRS 3.5 mm stereo jack
Line Output	1 - TRS 3.5 mm stereo jack
Setup Mic: (Audyssey)	1 - TS 3.5 mm stereo jack

Speaker Output	4 - Gold 5-way binding post
USB 2.0 Connection (Type A)	1
Local Area Network (LAN)	1 - RJ45

Supported Audio Formats

Music File (via USB or network)	MP3
	WMA
	AAC
	Ogg Vorbis
	FLAC
	WAV

Internet Radio:

Pandora
Sirius/XM
Rhapsody
Tuneln

IP Control

Apple iTouch[®]
Apple iPhone[®]
Apple iPad[®]
Android Mobile
Android Tablet

Network Connectivity

LAN (Wired Connection)	10/100base-t Ethernet
Wireless Connection	MIMO, 2 TX + 2 RX Channels IEEE 802.11a/b/g/n

Amplifier Output

Rated Output Power (8 ohm)	120W (60W x 2)
Two channels driven	20 Hz – 20 KHz @ 0.5% distortion
Rated Output Power (4 ohm)	120W (60W x 2)
Two channels driven	20 Hz – 20 KHz @ 0.5% distortion
Rated Distortion (1/2 Power)	0.20%
Speaker Impedance	4 – 8 ohms
Frequency Response (20- 20kHz)	+/-0.5 dB
Damping Factor	65+
Signal-to-Noise Ratio at rated output	92 dB A – weighted

Line Output:

Output Level	0-1000 mV RMS
Output Impedance	5 Ohms
Signal-to-Noise Ratio at rated output	88 dB A – weighted

Line Input:

Input Impedance	10 KOhms
Input Overload	2.3 V RMS

Audio Processing

Audyssey Dynamic Volume™	
Bass Equalization	+/-12 dB range
Treble Equalization	+/-12 dB range
Balance	

Regulatory Approvals

Safety	cTUVus, CE-LVD
EMC	FCC, IC, CE-EMC, C-Tick
Environmental Compliance	RoHS

Power Requirements

Input Voltage	100 – 240VAC, 50/60 Hz
Power Consumption (max)	150 W
Power Consumption (typical – 1/8 audio power)	31 W

Operating Temperature

0 °C to 40 °C

Physical Specifications

Unit Size (mm)	42 H x 229 W x 127 D
Unit Size (inch)	1.65 H x 9.02 W x 5.0 D
Unit Weight (kg)	1.11
Unit Weight (pounds)	2.45

Shipping Specifications

Unit Size (mm)	260 D x 240 W x 65.5 H
Unit Size (inch)	10.24 D x 9.45 W x 2.58 H
Unit Weight (kg)	2.0
Unit Weight (pounds)	4.41

NuVo reserves the right to change specifications without notice.

P3100 Player

Input/Output Connectors

Line Input	3 - TRS 3.5 mm stereo jack
Line Output	3 - TRS 3.5 mm stereo jack
Trigger Input	3 -TS 3.5 mm stereo jack
Trigger Output	3 -TS 3.5 mm stereo jack
Speaker Output	3 - (4 contact) Pluggable
USB 2.0 Connection (Type A)	3
Local Area Network (LAN)	1 - Dual RJ45

Supported Audio Formats

Music File (USB or over network)	MP3
	WMA
	AAC
	Ogg Vorbis
	FLAC
	WAV

Internet Radio

Pandora
Sirius/XM
Rhapsody
TuneIn

IP Control

Apple iTouch[®]
Apple iPhone[®]
Apple iPad[®]
Android Mobile
Android Tablet

Network Connectivity

LAN (Wired Connection) 10/100base-t Ethernet
Internal Ethernet switch to 3 independent zone nodes

Amplifier Output (typical of 3 zones)

Rated Output Power (8 ohm)	40W (20W x 2)
Two channels driven	20 Hz – 20 KHz @ 0.5% distortion
Rated Distortion (1/2 Power)	0.20%
Speaker Impedance	6 – 8 ohms
Frequency Response (20 - 20kHz)	+/-0.5 dB
Damping Factor	50+
Signal-to-Noise Ratio, rated output	92 dB A – weighted

Line Output:

Output Level	0-1000 mV RMS
Output Impedance	5 Ohms
Signal-to-Noise Ratio, rated output	91 dB A – weighted

Line Input:

Input Impedance	10 KOhms
Input Overload	2.3 V RMS

Audio Processing

Audyssey Dynamic Volume™	
Bass Equalization	+/-12 dB range
Treble Equalization	+/-12 dB range
Balance	

Regulatory Approvals

Safety	cTUVus, CE-LVD
EMC	FCC, IC, CE-EMC, C-Tick
Environmental Europe	RoHS

Power Requirements

Input Voltage	100 – 240VAC, 50/60 Hz
Power Consumption (max)	200 W
(typical – 3 zones, 1/8 audio power)	42 W

Operating Temperature

0 °C to 40 °C

Physical Specifications

Unit Size (mm)	44 H x 430 W x 250 D
Unit Size (inch)	1.73 H x 16.93 W x 9.84 D
Unit Weight (kg)	2.81
Unit Weight (pounds)	6.20

Shipping Specifications

Unit Size (mm)	565 D x 328 W x 130 H
Unit Size (inch)	22.24 D x 12.91 W x 5.12 H
Unit Weight (kg)	3.50
Unit Weight (pounds)	7.72

NuVo reserves the right to change specifications without notice.



NuVo Technologies, LLC, 3015 Kustom Dr., Hebron, KY 41048
www.nuvotechnologies.com
(866) 796-4904



NWAS 1246